

'PIH' Portable Immersion Heater

The EXHEAT 'PIH' range of portable immersion heaters are suitable for heating large or small quantities of liquid, stored in open topped vessels and baths, where permanently installed immersion heaters are not practical or desirable.

FEATURES

- Robust Stainless Steel construction
- IP66 Terminal enclosure
- Long life incoloy 825 sheathed rod type elements
- Wide, stable, self-supporting base
- Optional control thermostat
- Long unheated length for use with low liquid levels

TYPICAL APPLICATIONS

- Baptismal Pools
- Sterilizing
- Drum Heating
- Vat Heating



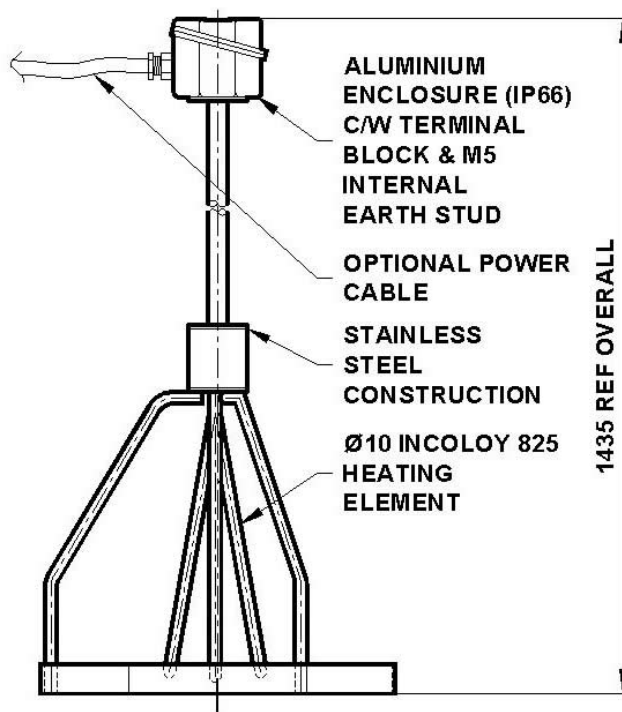

Enclosure	Self colour aluminium protected to IP66.
Element	Rod type with Incoloy 825 sheaths.
Immersed Parts	Stainless Steel.
Controls	Standard Construction – None. Automatic Construction - Capillary type thermostat.
Rating	Standard heater rating 3kW.
Voltage	Standard 240v single phase. Other single phase supplies on request.
Installation	We recommend that the electrical supply is protected by an RCD and that the heater is fully earthed. The element must be fully submerged before being energised.